



C42B

Pilot Operating Manual and Flight Training Supplement

Issue 4

C42B Pilot Operating Manual

This Manual belongs to aircraft reg : _____XXXX-XX_____

Type IKARUS C42B : _____XXX_____

Serial No. : _____XXX-XXX_____

Light Sport Aircraft (LSA).

LSA Types : **IKARUS** C42B 80, **IKARUS** C42B100,

Manufacturer: Aerosport Ltd,
Aerosport House,
Wolverhampton Airport,
Bobbington,
Stourbridge,
DY7 5DY.
UK.

Tel. +44 (0)1384 221550
Fax. +44 (0)1384 221560

This handbook should be kept with the aircraft.

1 CONTENTS

1	CONTENTS	3
2	ISSUE AMENDMENTS	4
3	GENERAL INFORMATION	5
4	AIRPLANE AND SYSTEM DESCRIPTIONS	7
4.1	Airframe	7
4.2	Power Plant	7
4.3	Propellers	8
4.4	Control Systems	8
4.5	Electrical System	9
4.6	Instruments	10
5	GENERAL OPERATING LIMITATIONS	11
5.1	Airframe Limitations	11
5.2	Control Deflection Limits	11
5.3	Rotax Powerplant Limitations	12
5.4	Propellers	12
5.5	Minimum Required Equipment	13
5.6	Operational limitations	13
5.7	Permitted Manoeuvres	13
5.8	Weights	13
6	OPERATION OF THE POWERPLANT	14
7	WEIGHT AND BALANCE INFORMATION	15
8	PERFORMANCE	17
9	WING RIGGING AND DE-RIGGING, FLYING WITH DOORS REMOVED	18
9.1	Rigging the wings	18
9.2	Attaching the wings to the folding mechanism	19
9.3	Folding The Wings	20
9.4	Flying with doors removed Aerosport MOD C42/019	21
10	SETTING (RIGGING) AND MISCELLANEOUS DATA	22
10.1	Incident angle of wing	22
10.2	Angle of Stabilizer	22
10.3	Control Surface Deflections	22
10.4	Air pressure for tyres and shock absorber:	22
11	FLIGHT	23
11.1	Engine Starting	23
11.2	Taxiing	24
11.3	Takeoff and climb	24
11.4	Cruising flight	25
11.5	Turning flight:	26
11.6	Slow flight, stalling and use of flaps:	26
11.7	Spin recovery	26
11.8	Descents, landing and roll out:	27
11.9	Shutting down the engine:	28
12	EMERGENCY PROCEDURES	29
12.1	Sudden loss of engine power:	29
12.2	Fire	29
12.3	Control System Failure	29
12.4	Emergency Locator Beacon Operation	30
12.5	Ballistic Parachute Operation	30
13	AIRCRAFT GROUND HANDLING AND SERVICING	31
13.1	Daily Inspection / Pre-flight Inspection	31
13.2	Periodic Maintenance and Inspection	31
13.3	25 Hour inspection	32
13.4	50 Hour Inspection	33
13.5	100 Hour or Annual Inspection	34
13.6	Jacking the Aircraft	35
13.7	Cleaning and Repair of the wing fabric	35
14	REQUIRED PLACARDS & MARKINGS	36
14.1	Aircraft and Engine Limitations	36
14.2	Secondary Control Markings	37
14.3	Fuel Filler	38
14.4	Oil Filler	38
14.5	Fuel Tank	38
14.6	Loading	38
14.7	Occupant Warning – Day VFR	38
14.8	Occupant Warning – Non Day VFR	39
14.9	Prohibited maneuvers	39
14.10	Unleaded Fuel Warning	39
14.11	LSA sign	39
14.12	Airspeed Indicator Markings	39

3 GENERAL INFORMATION

A record of all amendments is to be found in the front of this manual.

The C42 aircraft is a Light Sport Aircraft (LSA), conforming to the definition within LSA category.

To operate the aircraft the pilot must hold a license or certificate appropriate to this category of aircraft. The aircraft is not to be flown unless it is registered, carries registration markings in accordance with the requirements of the country in which the aircraft is to be flown, and has a Permit to Fly or certificate of Airworthiness valid in the country of operation. The aircraft is to be flown under daytime VFR conditions unless suitably equipped for non-VFR flight. Requirements equipment for non-VFR flight Flight into conditions other than VFR without the correct aircraft equipment and pilot ratings is extremely dangerous and can result in serious injury or death.

Pilots holding licences for other categories even higher ones are required to be checked out by an appropriately qualified instructor prior to flying this aircraft as it possesses characteristics that are unique to light sport type aircraft. These characteristics include low inertia, susceptibility to turbulence and wind gradient and special engine considerations.

The safety of all occupants, the aircraft and persons on the ground are the sole responsibility of the the Pilot in command. Do not operate this aircraft in a manner that would endanger the occupants, the aircraft or persons on the ground.

If the Neuform Variable Pitch propeller is fitted then documents reference NAM/C42/001 and NOM/C42/001 must be considered part of this Owner's Manual.

The engine of this aircraft is not certified, and could fail at any time. For this reason NEVER fly over congested areas or other areas on to which a safe landing cannot be made in the event of an engine failure. On cross country flights, ALWAYS keep an emergency landing field in sight.

Changes to the control system, structure, wings and engine are prohibited. These changes would invalidate any certificate of Airworthiness or permit to fly and as such would result in an insurance becoming null and void.

All operating difficulties and equipment failures should be reported to your dealer or the manufacturer.

Background

The aircraft is largely designed and manufactured by Comco Ikarus Gerätebau GmbH, based at Mengen Airport in Southern Germany. It is the natural successor to the Company's market leader, the C22, of which over 1200 examples have been built. To date over 310 examples of the C42 have been built and flown, including those powered by the 100 hp Rotax 912ULS.

The prototype C42 was first flown in 1995; the first production flight took place in Spring 1996. The lead aircraft has completed over 2400 hours. The C42 has been accepted in the UK by the Popular Flying Association (PFA) as a kit built and the CAA as a type approved series built microlight.

In the UK the Ikarus C42 FB 80 with a Rotax 912UL engine is approved by AAN 27832 and the Ikarus C42 FB 100 with a Rotax 912ULS engine is approved by this AAN 27832 Addendum 1.

Aircraft Description

The Ikarus C42 is a single engine, side by side, two seat light sport aircraft. It has a strutted high wing, with ailerons and simple flaps. Its tricycle undercarriage is fixed and incorporates shock absorption on all three wheels.

The C42 has optional power plants:

(i) The Rotax 912UL horizontally opposed, 4 cylinder 4 stroke engine, with watercooled heads and oil and air cooled cylinders; it has a capacity of 1211 cc and develops 80hp at 5800 rpm. The power is delivered to the fixed pitch propeller via a gearbox having a ratio of 2.27:1.

(ii) The Rotax 912ULS, with a similar configuration to the 912UL, but with a larger swept volume, higher compression ratio and developing 100 hp. Its gearbox has a ratio of 2.43:1.

The fuselage structure consists of a 165mm diameter alloy tube running from nose to tail, on which are mounted the engine, control system, seats, undercarriage and tail empennage. Wings are of conventional ladder construction with leading and trailing edge aluminium tubes connected by compression struts and braced internally by wires. Each wing half is covered by reinforced polyester fabric, fabricated as a sock, then heat shrunk into position.

The Build Standard of the aeroplane is defined on the Build Standard Sheet which is contained in the manufacturers Procedure P.01, "Control and Storage of Drawings, Configuration Control". The initial production standard of the type is Build Standard 1 which is contained in Issue 2 of Procedure P.01.

The aeroplane may be fitted with any propeller as approved in this manual.

4 AIRPLANE AND SYSTEM DESCRIPTIONS

The C42 is a simple aircraft whose structures and systems are readily inspected and maintained. However, since some of its systems differ from those found on conventional aircraft; this section should be studied before dismantling, repair or inspection.

4.1 Airframe

Fuselage

A 6.5" (165 mm) diameter aluminium tube runs from nose to tail and carries all the major assemblies: engine, seats, undercarriage, fuel tank, and tail empennage. The cockpit structure, consisting of a thin walled aluminium tube frame, includes a welded aluminium box-section frame at its top to which the wing spars' roots attach, and which provides compression load carry-through for both spars.

The composite seats are supported around their edges by attachment to the cockpit frame. Around the outboard edges of the seats, some of these loads are passed via the composite lower fairing to a lateral beam consisting of a 2.2" (56mm) reinforced box section. The ends of this beam accommodate the wing struts and withstand tension loads from them.

All load carrying (structural) members of the airframe are aluminium alloy tubes; most of which terminate in spherical bearings.

Wing

The wing has a ladder construction comprising leading and trailing edge tubes, connected by compression struts at intervals along its span. The triangulated wing struts, terminating at a fixed point at the top of the undercarriage, brace the wing against fore and aft loads. In normal +g flight these struts are under tension.

In +g flight both leading and trailing edge tubes inboard of the wing struts junctions, experience compression loads from the wing struts, as well as direct bending from lift loads.

The wing, tail empennage and all control surfaces are constructed of thin walled aluminium tubing. They are covered by a reinforced polyester fabric, sewn into complete envelopes and fitting tightly over their frames.

Undercarriage

The tricycle undercarriage has suspension on all wheels and damping on the main wheels. The front fork is directly connected to the rudder pedals. Hydraulic disc brakes operate on the main wheels only.

Main wheels' suspension stiffness can be adjusted by varying the air pressure in the damper units via the valves in their bases. A special high pressure pump is required for this purpose.

4.2 Power Plant

The 80 hp Rotax 912 or the 100 hp Rotax 912S is installed and drives the propeller via a gearbox with a reduction ratio of 2.27:1 or 2.43:1 respectively. Both power plants are flat 4 cylinder, 4 stroke engines with air and oil cooled cylinders and water-cooled heads. Full descriptions of the engine, its performance and maintenance requirements are to be found in the Rotax manual. Please see the relevant section for Engine limitations.

Exhaust system

The engine is fitted with a Hagerman Exhaust and Silencer System. This system is built largely from stainless steel components.

4.3 Propellers

The following propeller types are approved for use:

With the 80 hp Rotax:

Warp Drive CS68 composite 3 blade 68" (173cm) diameter propeller.
Neuform CR3 3 blade 69" (175cm) diameter propeller.

With the 100 hp Rotax:

A Warp Drive CS68 composite 3 blade 68" (173cm) diameter propeller.
Neuform CR3 3 blade 69" (175cm) diameter propeller.

All approved types have blades with ground-adjustable pitch and are set to the pitch angles given in Section 1. This pitch angle is prescribed at a specific radius from the point at which the blade exits from the hub.

The propellers have aluminium alloy hubs machined to close tolerances. This permits secure clamping of the blade roots under the high centrifugal forces experienced by the blades in service. Proper blade root securing bolt tension is essential to maintain this security.

Warp Drive and Neuform propellers blades are moulded in composite material, either carbon or glass fibre in epoxy resin. Blades of this type carry all of their strength and rigidity in the external skin, which is carbon or glass fibre braid or fabric. See Section 11.

4.4 Control Systems

Pitch

A central control stick, accessible by both occupants, is located over the fuselage between the seats. Fore and aft movement of this stick is transferred, via longitudinal push tubes, to a motion reversal lever installed midway between the cockpit and tail. This installation also accommodates the pitch stops. A second push tube, of similar length, runs from this lever to the elevator horn. A rearward movement of the stick lifts the elevator; forward movement depresses it.

Each push rod terminates in a spherical bearing (Rose joint) maintaining loads through the centres of the tubes. The threaded roots of these fittings can be susceptible to failure if bending loads are applied; it is important to ensure complete freedom of the joints at extremes of their movements, such that bending loads cannot be applied.

Roll

The stick is also connected to a torque tube mounted on top of the fuselage tube between the seats, and turning on a Rose joint at each end. The rear of the torque tube carries a pair of horns from which run control cables, one for each side. These cables are led behind and over the cockpit, via pulleys, to a central bellcrank. From here, motion is transferred via push tubes to a bellcrank in each wing, mounted on a wing compression strut forward of the aileron. A second tube links this bellcrank to the aileron horn.

The geometry of the aileron control system produces some asymmetry in the deflections of the

ailerons, effectively eliminating adverse yaw.

Movement of the stick to the right results in a lifting of the right hand aileron and depression of the left, and vice versa.

Yaw

Dual rudder pedals are mounted on common torque tubes, bearing in bushes installed directly into the fuselage tube. Control cables run from points near the top of the pedals' arms direct to the rudder horns.

Push rods connected to arms on the front fork, permit direct steering to be made via the rudder pedals. These push rods are curved to permit slight bending in the event of large opposing forces from two pilots being applied to the rudder pedals. In this event, a large proportion of the load is borne by the rudder cables themselves.

Two light springs are fitted to the rudder pedals to aid centering.

Pushing the right rudder pedal forward results in the rudder moving to the right; pushing the left pedal forward results in the rudder moving to the left.

Trim

An electric pitch trim system is controlled from a rocker switch in the dash. Pressing the top of the rocker switch lifts the trailing edge of the trim tab and results in a pitch down trim; pressing the bottom depresses the trim tab and results in a pitch up trim. The switch controls a small servo motor near the trailing edge of the fixed stabilizer. A short push rod runs from this servo motor to the trim tab horn. Raising the trim tab in flight results in a down deflection of the trailing edge of the elevator and a nose down pitch. A panel-mounted meter indicates trim position.

If the trim runs away to one extreme or fails in one position, no undue stick force is required to maintain control.

Brakes

The control stick carries a brake lever with an integrated master cylinder. Hydraulic lines carry pressure to a small disc brake on each of the main wheels. The brakes work together.

4.5 Electrical System

Electrical circuit diagrams are given on the following pages. Note that the MIPS electronic engine monitoring system is optional.

Battery

A small lightweight lead acid battery is installed between the rudder pedals on the main tube. It has a capacity of 5 amp hours and very high current capability. No maintenance is required, apart from keeping the contacts clean and dry. The battery is charged from the engine's in-built alternator, via a rectifier-regulator unit.

The engine ignition system is independent of the rest of the electrical system and does not require the battery to operate.

Fuses

Fuses are provided to protect wiring to all the electrical services with the exception of the starter motor. If a fuse blows, it is important to determine the cause of the failure before replacing the fuse. Under no circumstances replace the fuse with one of a higher rating.

4.6 Instruments

A variety of electrical instrument configurations is available, with an essential minimum as follows:

- Fuel gauge
- Tacho
- Cylinder Head Temperature gauge (CHT) *

*** Note: there may be a significant difference between the CHT reading and that of the coolant temperature, with the CHT gauge likely to read low, and to have a slower response. Although the CHT gauge may indicate an acceptable temperature, it must not be assumed that the coolant temperature lies within limits.**

Switches

A master switch provides isolation of the battery from the main bus. The master switch must be closed (on) before attempting to start the engine, and must remain on to ensure that the battery is charged properly.

Separate isolating switches are provided for the remaining services or groups of services. Where a radio is installed, it is wise to turn off the radio switch before starting to reduce the risk of high spurious voltages damaging the radio.

NOTE: - The ignition switches stop the engine by grounding the ignition circuit. The engine is started and runs with the switches open, and is stopped by closing the switches. The ignition switches are therefore mounted in the reverse sense to the other switches to enable the normal aviation switch sense to be maintained. ie. up for ON, down for OFF.

It is also important to note that disconnection of the ignition switch wires, by accident or during maintenance, renders the engine live. Great care must be exercised in this case to ensure that the engine cannot be started accidentally. Normally remove the spark plugs' caps.

5 GENERAL OPERATING LIMITATIONS

5.1 Airframe Limitations

Airspeeds - all speeds are Calibrated Air Speeds (CAS)

V _{NE} , Never Exceed Speed:	139 mph, 121 kt
V _A Max. manoeuvring speed,	97 mph, 84 kt
V _{SO} Stall speed, full flaps:	38 mph, 33 kt.
V _{S1} Stall speed, flaps retracted:	43 mph, 37 kt
V _{FE} Max speed :	70 mph, 61 kt

V_{NE} & V_A limitations are affected when flying with doors removed Aerosport MOD C42/019

Weights:

Empty weight (max):	621 lbs (282kgs) 80hp 912 611 lbs (278kgs) 100hp 912ULS
---------------------	--

Max gross weight:	1043 lbs (473 kg).
-------------------	--------------------

Areas:

Wing area	135 sq ft, 12.5 sq.m
-----------	----------------------

In-flight Structural limitations:

Positive limit load	4g (at all speeds)
Negative limit load	-2g

Centre of gravity limits: (Zero datum at the wing leading edge root)

Forward centre of gravity	13.8" (350) mm aft of datum.
Rearward centre of gravity	20.5" (523) mm aft of datum.

Airspeed markings:

White Arc:	37 to 72 mph (32 to 63 kt) —full flap operating range.
Green Arc:	47 to 94 mph (41 to 82 kt) — normal operating range.
Yellow Arc:	94 to 139 mph (82 to 121 kt) CAUTION, DO NOT USE IN TURBULENCE.
Red Line:	139 mph (121 kt) V _{NE} VELOCITY NEVER EXCEED.
Yellow Triangle:	60 mph, 52 kt - Recommended Minimum Approach Speed

5.2 Control Deflection Limits

At V_{NE} control surfaces should not be deflected more than one third full range.

V_A is the maximum speed permitted in turbulent conditions. Full deflection of the controls at speeds above V_A is prohibited.

6 OPERATION OF THE POWERPLANT

Description:

The Rotax 912 and 912ULS are 4 cylinder, four stroke, horizontally opposed engines. They are cooled by a combination of air-cooled cylinders and liquid cooled heads. The engine oil is also air-cooled with a small radiator.

Fuel Type: Min 91 Octane for the 80 hp, Min. 95 Octane for the 100 hp engine (RM/2 method) automotive gasoline leaded or unleaded or AVGAS 100 LL . Prolonged use of AVGAS can cause damage to the Rotax 912, precludes use of fully synthetic oil and requires more frequent oil and oil filter changes. Please study the Rotax engine operating manual.

CAUTION: Never handle the propeller with the ignition on.

To Start:	Main fuel valve,	OPEN
	Master switch	ON
	Electric fuel pump	ON
	Throttle at idle	FULL AFT
	Brakes	ON
	Mags (both)	ON
	Propeller area	CLEAR
	Rear of aircraft	CLEAR
	Choke (pulled out)	ON Start
	After engine starts, choke	OFF
	Check:	OIL PRESSURE RISING.

Note: If the engine doesn't start, repeat the procedure. If the engine floods, close the main fuel valve, half open the throttle and turn over the engine. When it starts, reduce the throttle quickly to idle (2000 rpm) and turn on the fuel.

Open the main fuel valve - don't forget!

Note: A water-cooled four stroke engine requires a fairly long warm up period. Run the engine at 2000 rpm for 2 minutes minimum then at 2500 rpm until the oil temperature is at least 120°F (50° C). Perform an ignition system check at 3500 rpm by turning off each ignition switch in turn. The engine speed drop should not exceed 300 rpm with a maximum difference of 120 rpm.

Failure to let the oil temperature reach 50°C can result in carburettor ice forming. It is imperative that this procedure is followed otherwise serious injury or death may result.

Engine

According to ROTAX Manual:

Oil Pressure:		29 – 72.5 psi (2 - 5 bar)
Oil Temperature:	min.	50° C
	max.	140° C (80hp), 130° C (100 hp)
	preferred range	90 - 110° C

Maximum coolant temperature 115°C

Maximum Cylinder Head Temp. (CHT)

912 (80hp)	150°C
912S (100hp)	135°C

Above CHT and coolant temperatures assume 50% glycol/water coolant mixture.

7 WEIGHT AND BALANCE INFORMATION

5.1 Minimum Required Equipment:

- a. Four point harness.
- b. Airspeed indicator 0-150 mph (0 - 130knots)
- c. Altimeter.
- d. Data placard and weight and balance document.
- e. Pre flight check list.
- f. Tachometer
- g. Cylinder head temp. or coolant temperature gauge.
- h. Oil pressure gauge
- i. Oil temperature gauge

5.2 Weight and Balance

The aircraft should be maintained in a configuration which meets the weight and balance criteria set out below. When this is the case, then by obeying the maximum placarded cockpit, baggage and fuel weights the centre of gravity will remain within the specified limits without further reference to weight and balance calculations.

5.3 Weight and Balance Calculations

The centre of gravity is measured in mm behind the zero datum. Zero datum is the leading edge root.

The aircraft's empty weight and cg are derived first: Place the aircraft in a level position on three scales, such that the stabilizer is horizontal, as shown below. Push down on the rear fuselage, just in front of the tail, and chock the nose wheel to level the aircraft. Record the reading of each scale.

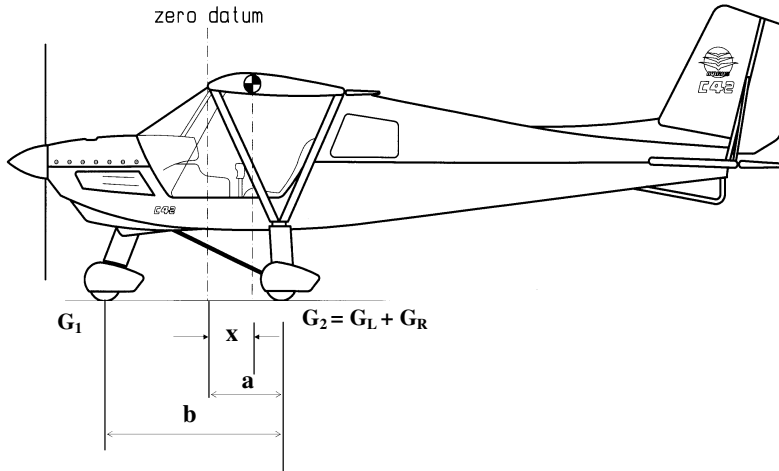

Calculate the position of the empty cg, from the formula:

$$X = a - \frac{G_1 \times b}{G_1 + G_2} = \dots\dots\dots mm$$

(a and b are values to be measured for the specific aircraft).

Insert the values for total empty weight, ($G_1 + G_2$) and cg distance aft of datum, (X), into the table on the following page. Multiply Empty Weight lbs (kg) by cg distance aft of datum inches (mm) to derive empty weight moment lbs.in (kg.mm) in the last column.

Complete the remaining weights for seat loads, fuel and baggage and multiply these by the lever arm lengths (given on the next page).

Add up the weights and moments, then divide the total weight by the total moment to give laden cg location aft of datum.

Loading plan

Position	weight x lever arm = moment		
	lb (kg)	in (mm)	lb in (kg mm)
Empty weight			
1. Seats		15.7 (400)	
2. Under seat bags		15.7 (400)	
3. Fuel		37.4 (950)	
4. Samsonite case		37.4 (950)	
Total Weight	lb (kg)	Total Moment	lb in (kg mm)
centre of gravity CG = $\frac{\text{Total Moment}}{\text{Total Weight}}$ = _____ = _____ in (mm)			

Allowable CG range 35(13.8" - 20.5" (350 - 523mm) behind zero datum (leading edge)

Ensure that this cg location lies within the limits 13.8" (350mm) to 20.5" (523mm) aft of datum.

5.4 Conditions of Weighing

The dry empty weight of the aircraft is defined under the following conditions:

- All normal installed equipment fitted.
- Oil and coolant levels normal.
- No usable fuel.

Note: **Remaining within the Maximum Take-off Weight (MTOW) of 1043lb (473kg) is the pilot's responsibility.**

8 PERFORMANCE

All versions:

Best climb rate speed (flaps 15% degrees, 1 stage)	70 mph (61 knots)
Min. sink rate at max. AUW (flaps 15 degrees, 1 stage)	450 fpm
Min. sink rate speed	52 mph (45 knots)
VS1 flaps up stall speed	43 mph (37 knots)
VS2 flaps 1 stage (15 degrees)	41 mph (35 knots)
VSo full flaps stall speed	38 mph (33 knots)
Roll rate at Va	±45 degrees in 2 sec's
Landing distance, from 15m fence	726 ft (220 meters)
Fuel consumption	See Rotax data.
Best glide angle	11:1

C42B 100 (Rotax 912S, 100 hp)

Take off distance, to clear 15m fence	672 ft (205metres)
Max. climb rate at max. AUW	1000 fpm
V _h max level speed at max. AUW	124 mph (108 kt)

C42B 80 (Rotax 912, 80 hp)

Take off distance, to clear 15m fence	720 ft (220metres)
Max. climb rate at max. AUW	700 fpm
V _h Max level speed at max. AUW	120 mph (105 kt)

9 WING RIGGING AND DE-RIGGING, FLYING WITH DOORS REMOVED

9.1 Rigging the wings

If you are tall but weak, it may be easier to manipulate the wing during rigging by holding it at its tip. If you are short and strong, the better handling point is the top of the wing struts. If you are short and weak, fetch a friend. If you are short, weak and friendless, don't derig.

Before attempting rigging, take a look at the wing roots and the way in which the rigging mechanism works. Note that the fulcrum (the roller bracket) is located near the wing root, and also in line with the rear spar attachment point. The front spar attachment point however is located some way inboard. This means that lifting the wing tip will result in the front spar clearing its fitting before the rear one. This can be used to advantage during rigging.

Step 1. Ensure that the spar channels in the cockpit roof are aligned with the top surface of the cockpit roof frame. Lock the controls, place the flap lever in the fully up position and ensure the brake is on.

Step 2. Bring the left wing strut into its correct position on the left wing and attach the auxiliary (jury) struts on the front and rear wing struts to the leading and trailing edge fittings.

Step 3. If this is the first side to be rigged and the second wing half is still resting on the tail, lift the wing at its tip with one hand. With the other hand, steadily lift the tail so that the aircraft rests on its nosewheel.

Step 4. Carry the wing into its 90° position relative to the fuselage, taking care not to damage the door and fuselage with the front spar.

Step 5. Turn the wing into a horizontal position and push it gently towards the fuselage.

Step 6. Lifting the tip, slowly insert the wing roots into position in their channels, leading edge first. It may be necessary to gently rock and twist the wing to engage the spar hooks on to their pins.

Step 7. Ensure that front and rear wing spars are properly engaged in their channels. Then insert the lower end of the wing struts into the open box-section end at the top of the shock absorbers.

Step 8. Attach front wing bolt and safety pin, using the tool provided.

Step 9. Attach rear wing bolt and safety pin.

Step 10. Attach the strut bolt through the box-section end and lower steel block of the wing struts ends. Install the safety pin.

Step 11. Check that all three bolts have their safety pins installed.

Step 12. As a final check, lift the wing at the wing tip to ensure proper attachment of the wing strut block to the box-section end.

Step 13. Connect the pitot tube to its fitting situated to the left of the pilot's headrest. Pull out the pitot tube forwards to its full extent.

Step 14. Repeat steps 1 through 12 for the other wing. Now you may remove the control lock.

Step 15. Attach right and left aileron push rods to the central bellcrank connection. Carefully ensure that the slide mechanisms of the special link connectors are properly engaged (closed and locked).

Step 16. On the flap drive tube, take the split sleeve fitted around the sprung taper pins (and

through which they protrude), spread it a little, then rotate it over the pins. Using this sleeve as an aid, squeeze it, thus compressing the pins. Then move the sleeve so that the drive fitting moves freely on its tube.

Step 17. Align the flap root tube and its drive fitting on the fuselage. Slide the flap drive fitting over the junction so that its cutaways engage snugly in the roots of the flap frame tubes and the sprung pins are fully out. Rotate the split sleeve so that its holes align with the tips of the pins again, permitting the pins to spring out fully. Left and right landing flaps must be securely locked and it may be necessary to wiggle the fitting a little to ensure proper engagement, particularly when the aircraft is new.

Step 18. Position and fasten the wing centre section (cockpit roof).

9.2 Attaching the wings to the folding mechanism.

The C-42 has an optional folding wing which minimises hangar space. For road transport however you must remove the wings completely. To attach the wings to the folding system:

Step 1. Fit the jockey wheel to the stern post, fit the triangular wooden support brackets to the bottom of the tailplane struts, with the aluminium strip uppermost.

Step 2. Remove the stop ring from the slide tube in the cockpit roof.

Step 3. Place a wing parallel to the fuselage with its tip supported on the tail by the wooden support bracket.

(With both wings folded back and supported by the tail, the aircraft will rock back to sit on its tail. With only one wing on the tail, the aircraft can be tipped forward to a stable attitude resting on its nose wheel. Be aware of these movements during rigging and derigging operations. Take care to protect the wing from damage by contact with the ground).

Step 4. Lift the wing root and slide the attachment block (roller) 2 inches (5cm) over the slide tube.

Step 5. Attach the stop cable on the leading edge to the quick link on the slide tube.

Step 6. Attach the stop ring to the end of the slide tube.

If both wings are in the folded back position the C42 can be easily moved by one person into a small hangar space.

9.3 Folding The Wings

If you have this option fitted :

- Step 1. Apply the brake. Fit the dolly wheel to the stern post.
 - Step 2. Push in the pitot tube on the left wing.
 - Step 3. Remove wing centre section.
 - Step 4. Disconnect the pitot tube from its fitting above the pilot's seat back.
 - Step 5. Place a triangular wooden support bracket (supplied) on to the lower part of the tailplane strut at each side, with the aluminium strip uppermost.
 - Step 6. Set the flap control in its fully up position.
 - Step 7. Disconnect the landing flaps by first spreading and rotating the aluminium split sleeve on the flap drive fitting. Then push in the spring loaded pins by squeezing the split sleeve.
 - Step 8. With the trailing edge of the flap resting on your shoulder, squeeze the split sleeve with one hand and, holding the knurled ring in the other, push the assembly inboard until it clears the drive tube junction. Lower the flap gently.
 - Step 9. Unlock the aileron push rods from central bellcrank connections.
 - Step 10. Remove the keep rings from the front and rear spar pins and the lower strut pin, at each side, (total 6 rings).
 - Step 11. Unlock the strut block from lower box section end by removing the strut pin, using the special tool provided.
 - Step 12. Unlock the rear wing spar by removing its pin.
 - Step 13. Unlock front wing spar by removing its pin, hold down the top of the screen to prevent damage.
 - Step 14. Close the door.
 - Step 15. Lift the left wing at its wing tip, or strut tops, so that wing strut block leaves the square box-section end. By lifting the wing high you will first disconnect the front spar hook from its pin and frequently the rear spar at the same time. If the rear spar does not disengage, gently rock the wing from side to side, pulling gently and twisting it until it does.
 - Step 16. Pull out the wing until it stops on the stop wire. Ensure that the stop wire runs over the TOP of the aileron operating push tube before folding back the wing.
 - Step 17. Draw back the wing away from the fuselage until the movement is stopped by the stop ring on the slide tube.
 - Step 18. Rotate the wing into a vertical position - underside of the wing to the front; trailing edge down.
- Always hold the wing tip higher than the root to prevent damage to the door and fuselage with the spars' ends.**
- Step 19. Carry the wing tip back into a position parallel to the fuselage. If the wing has been supported at the strut tops, it will be necessary to set it down and pick it up again by its tip for the next step. During this operation, ensure that the wing cannot tip forwards by walking your hands along the leading edge to the tip.

Note that the aircraft will tip back upon folding the second wing.

Step 20. Separate the Velcro for 2 or 3 inches (50 to 75 mm) along the aileron root at a point where the support bracket meets it.

Step 21. Place the wing trailing edge onto the retainer bracket on the tail.

Step 22. Remove the pin from the top of each jury strut.

Step 23. Rotate the jury struts carefully so that they lie parallel and next to each other.

Step 24. Undo the inboard zip on the wing's lower surface, adjacent to the jury struts.

Step 25. Fold in the main struts to lie flat against the lower wing surface. Secure the strut bottom with the bungee attached to the wing root.

Step 26. Fold back the right wing according to steps 1 to 25.

9.4 Flying with doors removed Aerosport MOD C42/019

Both doors must be removed. It is not permissible to remove just one door.

Ensure when flying with the doors removed that there are no loose items, take special care to check under the seats. Items stowed under the seat must be in a soft container that is unable to slide forward or interfere with the throttle (A suitable container is available from the manufacturer). Also wear suitable clothing that will not flap or flail around in the cockpit. It is recommended that maps are placed in a suitable map holder that can be anchored to the pilot or passenger.

Follow the instructions for removing and replacing the doors carefully.

- Open door and remove safety clip from gas strut and safety ring from rear clevis pin but do not unclip gas strut or remove clevis pin at this stage.
- Place a piece of tape over the hinge bolt to prevent it turning in or out.
- Carefully support the door and unclip the door strut ball joint then remove the clevis pin.
- Carefully slide the door off the front locating spigot & store the door somewhere safe.
- Re-fitting is simply a reversal making certain to re-fit safety rings & clips

10 SETTING (RIGGING) AND MISCELLANEOUS DATA

10.1 Incident angle of wing

Incident angle of wing with respect to main fuselage tube: 8°

Note: The incident angle is defined as the angle between a line parallel to the fuselage tube and a line joining the undersides of the leading and trailing edge tubes at their roots.

10.2 Angle of Stabilizer

Angle of stabilizer with respect to the main fuselage tube: 7°

Note: The stabilizer angle is defined as the angle between a line parallel to the fuselage tube and a line joining the undersides of the leading edge and trailing edge of the stabilizer.

Angle difference between wing and stabilizer: 1°

10.3 Control Surface Deflections

Aileron Up 20 ±2° or 3.35" (85 mm), ±0.35" (9 mm) measured 9.84" (250 mm) from the hinge axis.

Down 14° ±2° or 2.36" (60 mm), ±0.35" (9 mm) measured 9.84" (250 mm) from the hinge axis.

Area 6.24 ft² (0.58 m²) per side.

Elevator Up 30° ±3° or 8.07" (205 mm) ±0.83" (21 mm) measured 16.14" (410 mm) from the hinge axis.

Down 20° ±3°. Or 5.51" (140 mm) ±0.83" (21 mm) measured 16.14" (410mm) from the hinge axis.

Area 8.83 ft² (0.82 m²) total

Rudder L/R 32° ±3° or 8.54" (217 mm) ±0.83" (21 mm) measured 16.14" (410mm) from the hinge axis.

Area 4.74 ft² (0.44 m²) total

Fin Area 6.57 ft² (0.61 m²) total

Stabilizer Area 15.28 ft² (1.42 m²) total

Flaps - 4.5° -15° - 42°
Relative to the fuselage tube.

Area 4.95 ft² (0.46 m²) per side.

Elevator Trim Tab Up 1 to 5°
Down 25°±3° (relative to elevator)

10.4 Air pressure for tyres and shock absorber:

Main wheels 26 to 36 psi (1.8 - 2.5 bar).
Front wheel 22 to 26 psi (1.5 - 1.8 bar).

Shock absorbers 425 to 486 psi (29 - 33 bar).

11 FLIGHT

All checklists below are suggestions only. Your Flying Instructor may prefer these checks to be carried out in a different order or to include other items. It is the Pilot in command's responsibility to ensure that the aircraft is fit for the flight intended.

11.1 Engine Starting

Description:

The Rotax 912 and 912S are 4 cylinder, four stroke, horizontally opposed engines. They are cooled by a combination of air-cooled cylinders and liquid cooled heads. The engine oil is also air-cooled with a small radiator.

Fuel Type: Min 91 Octane for the 80 hp, Min. 95 Octane for the 100 hp engine (RM/2 method) automotive gasoline leaded or unleaded or AVGAS 100 LL . Prolonged use of AVGAS can cause damage to the Rotax 912, precludes use of fully synthetic oil and requires more frequent oil and oil filter changes. Please study the Rotax engine operating manual.

CAUTION: Never handle the propeller with the ignition on.

To Start ensure that :

Brakes	ON
Aircraft	FACING A SAFE DIRECTION AND AREA CLEAR ALL AROUND
Flaps	NEUTRAL
Non essential electrics	TURNED OFF
Carb Heat	OFF
Main fuel valve,	OPEN
Master switch	ON
Electric fuel pump	ON
Throttle at idle	FULL AFT
Magnetos (both)	ON
Propeller area	CLEAR
Rear of aircraft	CLEAR
Choke	PULLED OUT
Shout	"CLEAR PROP"
START ENGINE	
After engine starts, choke	OFF
Check:	OIL PRESSURE RISING*.

*** If Oil pressure does not rise turn off engine immediately.**

Note: If the engine doesn't start, repeat the procedure. If the engine floods, close the main fuel valve, half open the throttle and turn over the engine. When it starts, reduce the throttle quickly to idle (2000 rpm) and turn on the fuel.

Open the main fuel valve - don't forget!

Note: A water-cooled four stroke engine requires a fairly long warm up period. Run the engine at 2000 rpm for 2 minutes minimum then at 2500 rpm until the oil temperature is at least 120°F (50° C). Perform an ignition system check at 3500 rpm by turning off each ignition switch in turn. The engine speed drop should not exceed 300 rpm with a maximum difference of 120 rpm.

Failure to let the oil temperature reach 50°C can result in carburettor ice forming. It is imperative that this procedure is followed otherwise serious injury or death may result.

After Start

- Aircraft holding on brakes
- Aux fuel pump OFF
- Oil pressure within limits
- Set rpm to 2000 (2500 rpm if cold and requires warming)
- Choke is OFF
- Check idle
- Charging lamp showing OFF
- Radio ON (If fitted)
- Check clear for taxi
- Reduce throttle to idle before releasing brake

11.2 Taxiing

During Taxi

- Brakes operating properly
- Check compass and slip ball
- Use elevator as necessary to keep the weight off the nose-wheel

The nose wheel steering is conventional and is directly connected to the rudder pedals. Push the right pedal to turn right. Push the left pedal to turn left. Taxiing is simple; the turning radius of the C42 is small, and the aircraft handles cross winds during taxiing very well.

When taxiing with a strong tail wind, hold the control stick firmly in the neutral position.

When taking off or landing on bumpy grass strips, exercise caution to avoid striking the propeller. This may require performing soft field take-off and landing procedures.

Note: with a fully aft cg it is possible for the aircraft to tip back and sit on its tail skid, particularly if taxiing over uneven ground.

11.3 Takeoff and climb

Pre-Flight Vital Actions

- Park into wind
- Brakes on and locked
- Set throttle at 2000 rpm (If still warming 2500 rpm)
- Controls full and free and correct sense
- Harnesses and hatches secure (no light visible along bottom of door)
- Loose items stowed
- Flight instruments set and correct
- Engine temperatures and pressures within limits
- Magneto check at 3500 rpm (max drop 200 rpm)
- Throttle to idle (1450 -1600 rpm)
- Reset throttle to 2000 rpm
- CARB Heat on (check slight RPM drop)
- Fuel ON and contents sufficient for flight
- Aux fuel pump ON
- Trim set for take off
- Flaps set 1 stage (15 degrees) if required
- CARB Heat off.
- Check ALL CLEAR
- Check full power during take off roll (min 5000 rpm)

Complete the pre-take checklist 'VITAL ACTIONS' above. Ensure the trim is set to one step above neutral, as indicated by a centre-scale reading on the trim indicator and the flaps are set as

required (Max 1 stage, 15 degrees). Always take off into the wind when possible. The maximum demonstrated 90 degree crosswind component is 17 mph (15 knots).

The stick position should be positively aft of neutral and maintained during the ground roll to minimise the loading on the nose wheel. Smoothly bring the throttle to the full forward position, check the tachometer for full throttle rpm.

It will be necessary to hold right rudder to counteract slipstream effect and engine torque during the ground roll and climb out. The nose wheel lifts off at approximately 30 mph, (26 kt). Accelerate with the nose wheel off the ground 2-4 inches, (5-10 cm). The aircraft will take off at 44 mph (38 kt).

After takeoff, let the aircraft accelerate to the best rate of climb speed V_y 70 mph, (60 kt), 1 stage flap extended. At between 150 and 200 ft raise the flaps to the cruising flight position (0 degrees or no flaps). Be ready for the pitch trim change to nose-down. Trim the aircraft as required for the climb. Recommended full power climb 80 hp 71 – 76 mph (62 - 66 kts). Recommended full power climb 100 hp 76 – 80 mph (66 - 70 kts).

Best angle of climb speed V_x is 55 mph, (48 kt) (1 stage flaps). However this climb speed and angle are not recommended because in the event of an engine failure it is possible that control of the aircraft may be lost. The aforementioned procedure is therefore recommended. This should ensure full control is maintained in the event of an engine failure shortly after takeoff providing immediate engine failure action is taken.

Cross wind take off :

Take off should be made as described above but with into wind aileron. Maintain track down the centerline with rudder and further maintain into wind aileron as required to stop your drift during the take off roll and rotation. (Out of wind wing main wheel can lift off first during take off). Resume wings level balanced flight after take off.

The maximum demonstrated 90 degree cross wind component is 17 mph (15 kts)

After Take Off

Flaps up above 150 feet
Aux fuel pump off above 1000 feet
Engine temperatures and pressures within limits

11.4 Cruising flight

Note: Typical economic cruise speeds lie in the range 80 to 105 mph (70 to 90 kt); 109 mph (95 kt) with the 100 hp engine.

Maximum continuous engine speed is 5500 rpm for the 80 hp and 100 hp.

Variations in rpm and cruise performance occur with different loads.

Typical cruising flight (80 hp)

Engine speed: 4500 rpm.
Airspeed: 95 mph (83 kt)
Fuel flow: 3.4 US.gallons per hour, (12.7 l/h)

The maximum speed in cruising flight is 118 mph (103 kt).

Note: *This maximum speed applies only in smooth conditions with no turbulence. In turbulent air, speed must be kept below $V_A = 97$ mph (84 kt).*

11.5 Turning flight:

In turning flight, it is necessary to co-ordinate the use of the ailerons and the rudder. At normal cruising speeds 80 mph (70 kts) to 103 mph (90 kts) initiate the turn with aileron maintaining balance as necessary with rudder. At bank angles exceeding 45 degrees the pitch trim force required to maintain level flight increases noticeably. Banks exceeding 60 degrees are prohibited. In steep bank turns remember to maintain the attitude at entry and maintain airspeed with power. Failure to maintain correct attitude can result in a spiral dive developing. At 60 degrees of bank the stall speed is multiplied by a factor of 1.41 and you will be pulling 2g.

11.6 Slow flight, stalling and use of flaps:

In cruising flight configuration with the landing flaps retracted and at speeds below 60 mph (52 kt) the top of the engine cowl will be well above the horizon. Control inputs of the aileron and rudder will be severely dampened and the overall response of the aircraft markedly reduced. Only gentle turns should be made of up to 20 degrees of bank ensuring the aircraft remains in balance. In slow flight if a wing drops, centrally reduce back pressure on the stick and lower the nose. Prevent further yaw with the rudder and do not attempt to lift the wing by aileron input. At approximately 48 mph (42 kt) there will be a slight buffeting of the airframe. The aircraft is still controllable. However, aileron input should not be used and the stick kept central with any tendency for the wing to drop use opposite rudder to prevent yaw.

If stalls are entered very gently the aircraft can enter a controlled mushing descent, control can still be maintained with rudder. (It is important not to over use rudder and potentially put the aircraft into a reverse spin entry).

When the aircraft stalls the nose will drop. By removing back pressure the aircraft should recover. Typical height loss in the wings-level stall is approximately 100 ft., and max. Pitch attitude change 25° below the horizon. In turning flight stalls the typical height loss is 120 ft. At full flap (40 degrees) the pre-stall buffet, 39 mph (34 kts), is markedly more noticeable and there is an increased tendency for the wing to drop if balanced flight is not maintained.

Speeds are as follows:

VS1 flaps retracted (0°) 43 mph, (37 kts)

VS2 first notch of flaps (15°) 41 mph, (35 kts)

VS0 full flaps (40°) 38 mph, (33 kts)

The above specified stall speeds will vary slightly depending on the all up weight.

11.7 Spin recovery.

Immediately, reduce power to idle centralise the controls and remove any flap, then apply full opposite rudder to the direction of the spin. Move the stick centrally forward centralising the rudder as rotation ceases and ease out of the dive. Avoid over speeding the aircraft during the pull out.

Intentional Spinning is prohibited. Spinning can result in serious injury or death.

11.8 Descents, landing and roll out:

Downwind/Airfield Approach checks.

- Altimeter set to QFE
- Brakes off
- Aux Fuel pump on
- Sufficient Fuel for Go-around
- Engine temps and Pressures OK
- Carb heat on
- Airfield Activity

Base leg

Flaps set one stage

Final

- Carb heat Off
- Flaps Set to two stages (if required)
- Check Clear to land

Entering a conventional circuit in the cruise 92 mph (80 kts) when on the base leg reduce power, maintaining attitude allowing a reduction in airspeed to 72 mph (63 kts) (white arc) select 15 degrees flap (1 stage) simultaneously lowering the nose to maintain 67 mph (58 kts) and trim.

On final approach if the crosswind component is less than 12 mph (10 kts) you can select full flaps simultaneously lowering the nose to maintain 55 kts. Continue your approach at 63 mph (55 kts) and trim if required. Minimum approach speed in this configuration is 60 mph (52 kts).

In calm conditions it is acceptable to use side slip technique to increase your rate and angle of descent, but it is recommended the aircraft is returned to a standard approach configuration before reaching 100 ft above the runway.

In the landing phase during the hold off when the main wheels touch ensure that the nose wheel is maintained clear of the runway during the landing roll bringing the stick steadily rearward until it reaches the backstop and allow the nose wheel will settle onto the runway as the speed decays.

Caution should be exercised when applying brakes as it is possible to lock the main wheels under certain conditions. It is preferable to allow the aircraft to de-accelerate to a walking pace before applying any braking action.

Cross wind landing technique

Establish the aircraft on a powered approach, tracking the centreline and allowing for drift. For crosswind components of 12 mph (10 knots) or above only 1 stage of flap (15 degrees) is recommended. Approach speed should be 66 mph (58 kts).

The generic wing down approach is recommended. If you are not fully aware of crosswind techniques you should consult an approved instructor. The following description is for guidance and not a substitute for proper instruction.

Below 200 feet on the approach, apply rudder to align the nose of the aircraft with the centreline of the runway simultaneously lowering the into-wind wing with aileron to maintain your track down the centreline (preventing drift).

Smoothly allow the aircraft to settle on to the runway, the "into wind" wheel will contact the runway first maintaining directional control with the rudder and progressively increase the into-wind aileron deflection as the airspeed reduces.

Allow the nose wheel to settle on to the ground earlier than normal to transfer steering authority.

Avoid "fully holding off" before touchdown as drift angle increases and airspeed decays, the control authority also reduces.

Once you have cleared the active runway :-

Flaps	UP
Aux Fuel pump	OFF
Landing lights	Off

11.9 Shutting down the engine:

During the descent and subsequent taxiing, the engine will have cooled down enough to permit immediate shut-down after parking.

Turn off all electrical accessories and radios before shutting down the engine.

- Brakes On
- Set RPM 2000
- Magnetos check
- Radio, transponder & Nav aids off.
- Throttle to Idle
- Aux Fuel pump Off
- Lights Off
- Check Hobbs reading
- Magnetos Off
- Strobe Off
- Master Switch off.

12 EMERGENCY PROCEDURES

12.1 Sudden loss of engine power:

Set attitude for **best glide at 58 knots** and trim (This is a good compromise speed and easy to achieve quickly). Assess the wind direction and select a suitable landing area into wind. Plan your approach and execute this action.

If you have time check the reason for engine failure:

Master switch ON
Magneto switches ON
Fuel tap ON
Choke OFF

Try restart:

Auxiliary fuel pump ON
Throttle set 1/4 open
Press starter

If restart not achieved and you still have sufficient height and time make a MAY DAY call. Stay on the frequency you are already on if contact established. Remember it is more important to keep flying the aircraft on your planned approach than any other action.

Do not turn your back on the planned landing site or make a 360 degree. A constant aspect approach is recommended coupled with beats and turns and or sideslip to increase rate of descent.

IMPORTANT: SHUT DOWN CHECKS (Prior to landing)

Throttle closed
Master OFF magnetos OFF
Fuel OFF
Security - harnesses tight, reassure passenger

1 Stage of flap can be applied at any time during your descent.

During your initial approach you should be aiming at the middle of the landing site bringing your aiming point back to one third in after applying full flap. All emergency landings should be made into wind with full flap to minimize landing speed.

Remember - KEEP FLYING THE AIRCRAFT AT ALL TIMES.

12.2 Fire

In the event of carburetor or engine fire:

Main fuel valve off .
Electric fuel pump off.
Full throttle, (to burn the remaining fuel fast).
Maximum permissible airspeed to put out the flames.
Call MAYDAY
Follow emergency landing procedures.

12.3 Control System Failure

I Should you lose elevator control due to a mechanical failure, trim the aircraft to 65 mph (56 knots). With a reduced power setting, make a shallow power-on landing approach, throttle back and flare using the trim. Avoid use of the flaps.

II If you lose aileron control, you can fly the aircraft with rudder alone.

III If you lose rudder control, the aircraft can be flown with the ailerons alone.

12.4 Emergency Locator Beacon Operation

Please see operating instructions supplied by manufacturer with Aircraft.

12.5 Ballistic Parachute Operation.

The optional ballistic parachute system is a rocket deployed system using a pyrotechnic mounted in the fuselage. The system must be made safe once the aircraft is on the ground by securing the firing mechanism with the supplied lock. The lock should be removed before each flight. It is imperative that use of the parachute system is included in the pre-flight briefing of any occupants. The system is activated by pulling down hard on the red handle located in the roof of the cockpit between the occupants.

More detail instructions for the use of the recovery system are available in ballistic recovery system manufacturer's manual supplied with the aircraft.

13 AIRCRAFT GROUND HANDLING AND SERVICING

13.1 Daily Inspection / Pre-flight Inspection

1. Engine and cowling secure and undamaged.
2. Check coolant level correct.
3. Check oil level within limits.*
4. Propeller clean and undamaged¹, bolts secure.
5. Front gear; tyre pressure, tyre condition and tyre creep.
6. Left main gear; tyre pressure and condition.
7. Left side wing, structure and covering.
8. Left wing strut attachment secure.
9. Left aileron, control linkage and hinges secure.
10. Left flap, control linkage and hinges secure.
11. Left side of the fuselage, undamaged
12. Tail group secure and surfaces undamaged.
13. Elevator hinges and control linkage secure.
14. Trim tab and linkage secure.
15. Rudder hinges and control cables secure.
16. Repeat items 4 thro' 9 for right side.
17. Fuel filler cap secure.
18. Windscreen clear and undamaged.
19. ASI pitot unobstructed and extended to end of red mark.
20. Cockpit area inside and out, check controls full movement, free and correct sense.
21. Instruments serviceable.
22. Open fuel tank sump drain and check for contamination.
23. Check tank water drain for leaks.

**When checking the oil level it may be necessary to pump the oil back into the reservoir to obtain a correct reading and to avoid overfilling. This can be done by removing the oil filler cap and ensuring the master switch and magnetos are off and rotating the propeller ONLY in the operating direction until a gurgling sound is heard from the reservoir tank.*

¹ With composite propellers, minor damage to the external surface, such as a deep scratch which breaches the outside fabric, can result in significant loss of strength and a dangerous condition. For this reason it is important to inspect the blades carefully before flight. Look particularly for scratches along the chord of the blade which may have severed one or more yarns of fibre. When in doubt, seek expert advice.

13.2 Periodic Maintenance and Inspection

Servicing, maintenance, repair work and inspections on this class of aircraft can only be performed by personnel qualified according to the LSA requirements. Use only approved spare parts and never fit damaged parts.

13.3 25 Hour inspection

Engine: Check 25 hour inspection items in accordance with the ROTAX manual.

Fuel system

1. Check tank internally for cleanliness.
2. Check fuel filter for cleanliness.

Airframe

1. Check control stick for freedom without undue friction.
2. Check safety lock plates at the bearings at front and rear ends of control stick torsion tube.
3. Check that rod end bearings on elevator push rods suffer no bending at each extreme lateral position of stick (aileron limits).
4. Check all lock nuts for tightness.

Wing

1. Check internal bracing wires for adequate tension.
2. Check freedom of ailerons.
3. Check aileron and flap hinges for wear.
4. Check aileron and flap hinge bolts for tightness (cannot rotate)

Tail Empennage

1. Check rudder hinges for wear.
2. Check elevator hinges for wear.
3. Check rudder and elevator hinge bolts for tightness (cannot rotate)
4. Check rudder cables for wear at fairleads.

13.4 50 Hour Inspection

Engine and Fuel System

Check inspection items in accordance with the ROTAX manual.

Additionally to 25 hour inspection

1. Check rudder and aileron cables for wear and damage.
2. Check brake pads, brake disks and brake function.
3. Lubricate the nose leg bearings with a grease gun at the upper and lower grease nipples.
4. Check rudder cable tension, 55lb to 77lb (25 to 35 kgf).
5. Check aileron cable tension, 40lb to 53lb (18 to 24 kgf).
6. Change the fuel filter.
7. Check stub axles for cracks.
8. Check seat support tube cannot rotate.

13.5 100 Hour or Annual Inspection

Engine

Perform 50 hours checks in accordance with ROTAX manual.

Additionally to the 50 hour inspection

1. Clean, grease and check security of ball joints on steering rods at foot pedals and operating bar of front wheel.
2. Clean, grease and check security of rod end bearings at stick torsion tube.
3. Clean grease and check freedom of throttle control; ensure that the cable cannot stick, even when closed slowly.
4. Clean, grease and check security of all ball and fork hinges at each aileron push rod end.
5. Check all hinges for excess play.
6. Check all lock nuts for proper installation; check 2 threads showing.
7. Check central and internal wing-mounted aileron bellcranks for freedom and security. Clean and grease bellcrank ball connections, and, if necessary, bellcrank bearings.
8. Check cross bolt and connections of elevator motion reversal lever for security and wear. (Mounted on rear fuselage).
9. Check bearing of reversing lever for wear and freedom. Clean and grease central bearing.
10. Clean, grease and check security of rod-end bearings of elevator push rods; tighten and Loctite locking nuts.
11. Remove exhaust and check for cracks especially around cockpit heater jacket.

Replace cockpit carbon monoxide detector in accordance with manufacturers instructions.

13.6 Jacking the Aircraft

Either of the main wheels can be brought clear of the ground by one person lifting the wing at the top of the wing struts. (Never apply any significant up load to the centre of the struts). The aircraft can then be chocked by placing a wooden block under the bottom part of the stub axle. This is also a suitable jacking point where a second person is not available to lift the wing.

The nose wheel is easily lifted by applying a load to the rear fuselage, just forward of the tail. Where one person only is available, place weights on the tail, suitably padded to prevent damage to the fabric, until the nose wheel becomes light. Place a piece of timber under the tail skid, then push the tail down on to it. Add further weights to the tail to stabilise the aircraft in this attitude.

13.7 Cleaning and Repair of the wing fabric

Cleaning

Clean the wing coverings with warm water and a mild detergent, such as washing up liquid, to remove oil. Never use solvents. All metal parts are anodized aluminum or stainless steel and need no special attention.

Dirt or mud on wing surfaces should be removed with clean water. Avoid the use of a pressure washer or hose pipe as this can introduce water into places it shouldn't go, (engine, fuel tank, pitot head, pilot's seat).

Repair

Repair even the smallest tears in the covering fabric.

Carefully clean the area around the tear, then attach a small patch with contact adhesive covering an area at least 15 mm larger than the damage all round. Alternatively apply a small patch of self-adhesive material. For larger areas of damage, consult your dealer or the manufacturer.

In the event of technical problems, contact your dealer or the manufacturer.

14 REQUIRED PLACARDS & MARKINGS

The following placards are fitted to the aircraft, in the locations indicated:

14.1 Aircraft and Engine Limitations

Within pilot's view

For the 100hp:

V _{NE}	139 mph (121 kt)
V _{FE}	70 mph (61 kt)
RPM max. (5 mins)	5800 rpm
RPM max. continuous	5500 rpm
Oil pressure	29 – 72 psi (2 - 5 bar)
Oil Temp.	Min. 50°C
Oil Temp.	Max. 130°C
CHT	Max. 135°C

For the 80hp:

V _{NE}	139 mph (121 kt)
V _{FE}	70 mph (61 kt)
RPM max. (5 mins)	5800 rpm
RPM max. continuous	5500 rpm
Oil pressure	29 – 72 psi (2 - 5 bar)
Oil Temp.	Min. 50°C
Oil Temp.	Max. 140°C
CHT	Max. 150°C

Flying Without Doors:
Aerosport MOD C42/019

Flying Without Doors
Aerosport MOD
C42/019
V _{NE} 103 mph (90 kt)
V _A 80 mph (70 kt)

14.2 Secondary Control Markings

The following secondary controls are marked for function and operation:

Trim - next to the trim rocker switch.

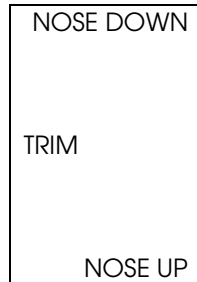

Flaps - next to the flaps control lever:

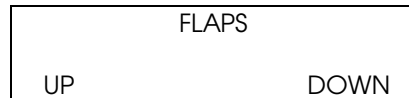

Fuel Tap- next to the fuel tap:

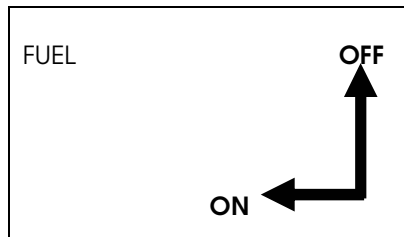

Starter - next to the starter button

STARTER

Choke - next to the choke:

CHOKE

14.3 Fuel Filler

Position next to the fuel filler:

For the 100 hp Rotax:

Unleaded Premium Auto GAS
Minimum Fuel Grade
MON 85, RON 95, AKI 91
AVGAS 100LL
Avoid prolonged use of Avgas

For the 80 hp Rotax:

Unleaded Premium Auto GAS
Minimum Fuel Grade
MON 83, RON 91, AKI 87
AVGAS 100LL
Avoid prolonged use of Avgas

14.4 Oil Filler

Position - near the oil filler:

Use synthetic or semi-synthetic oil.
Specification API SG, SF or higher.
See Rotax manual for oil
recommendations

14.5 Fuel Tank

Position - near the fuel filler:

Usable fuel capacity
17 US Gallons (65 litres)

14.6 Loading

Position : within Pilot's view

Empty weight	<input type="text"/>
Max. weight	1043lb (473kg)
Min. cockpit load	120lb (55kg)
Max. weight per seat	264lb (120kg)

14.7 Occupant Warning – Day VFR

Position : within Occupant's view

This aircraft was manufactured in accordance with Light Sport Aircraft airworthiness standards and does not conform to standard category airworthiness requirements. To be flown Day VFR only.

14.8 Occupant Warning – Non Day VFR

Position : within Occupant's view

This aircraft was manufactured in accordance with Light Sport Aircraft airworthiness standards and does not conform to standard category airworthiness requirements.

14.9 Prohibited maneuvers

Position : within Pilot's view

NO INTENTIONAL SPINS

14.10 Unleaded Fuel Warning

Position : within Pilot's view

USE OF UNLEADED MOGAS
(See Airworthiness Notice 98B & C)
* Only legal in aircraft specifically approved for the purpose.
* Fuel to be fresh, clean, alcohol and water free.
* Check for leaks and deterioration of pipes, fittings, valves.
* Verify take-off power prior to committing to take-off.
* Tank fuel temperature not above 20°C.
* Fly below 6000 ft.
CARB ICING AND VAPOUR LOCK MORE LIKELY

14.11 LSA sign

Position : On the side of the cage facing the doors

Light Sport

14.12 Airspeed Indicator Markings

Position Placarded on instrument

White Arc:	38 to 70 mph (33 to 61 knots) —full flap operating range.
Green Arc:	43 to 97 mph (37 to 84 knots) — normal operating range.
Yellow Arc:	97 to 139 mph (84 to 121 knots) CAUTION, DO NOT USE IN TURBULENCE.
Red Line:	139 mph (121 knots) V_{NE} VELOCITY NEVER EXCEED.